

AudioWind Electronics-Salon

SPECIFICATION

Model: A-210EP

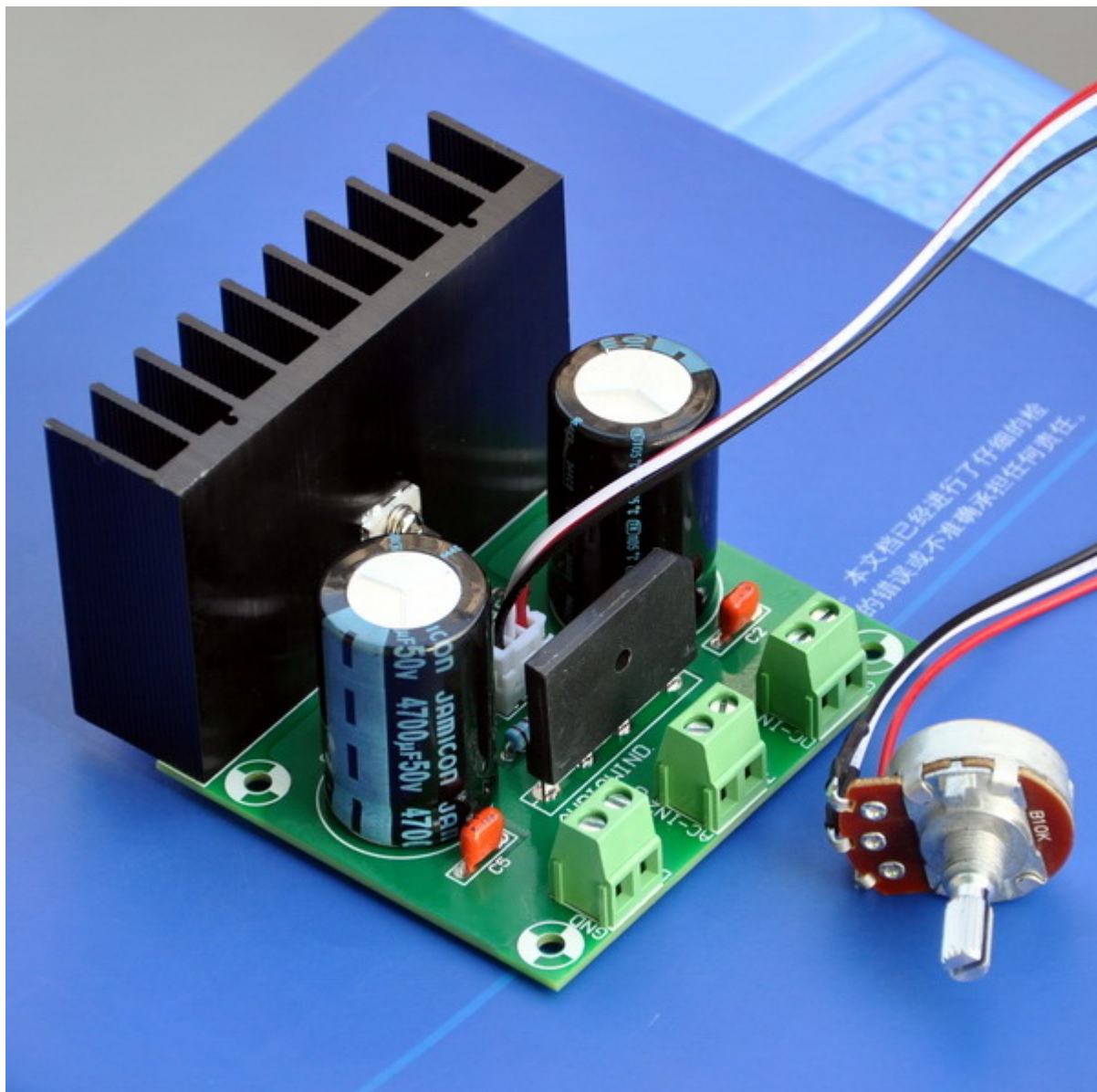

Power Supply Board Based on [National Semiconductor LM338T](#) Regulator IC Design, AC or DC Input, DC Output.

LM338T Datasheet: <http://www.national.com/ds/LM/LM138.pdf>

Specifications:

Input Voltage	DC: 4 to 35V DC
	AC: 4 to 26V AC
DC Output Adjustable Range	1.5V to 32V
Initial Set Output Voltage	12V DC
Maximum Continuous Output Current	DC: 5 Amps *1
	AC: 3 Amps (Rectifier Without Heatsink) *2
	AC: 5 Amps (Rectifier With Heatsink) *2
Module Size	80 x 76.2 x 55 mm (L x W x H)
	3.15 x 3 x 2.2 inch (L x W x H)
IC Heat-Sink Size	22.5 x 50 x 76.2 mm
PCB Size	66 x 76.2 mm

Other electrical specifications, please read the LM338T datasheet.

Note:

*1: This module must be less than 25 watts itself power consumption, please calculate the power consumption:

For DC Input: $(V_{inDC} - V_{out}) \times I_{out} < 25 \text{ watts}$

For AC input: $((V_{inAC} \times 1.4) - 1.8) - V_{out}) \times I_{out} < 25 \text{ watts}$

*2: This module no include bridge rectifier heatsink.

Caution: IC heatsink connected DC-Output.

Module Dropout Voltage VS Maximum Continuous Output Current:

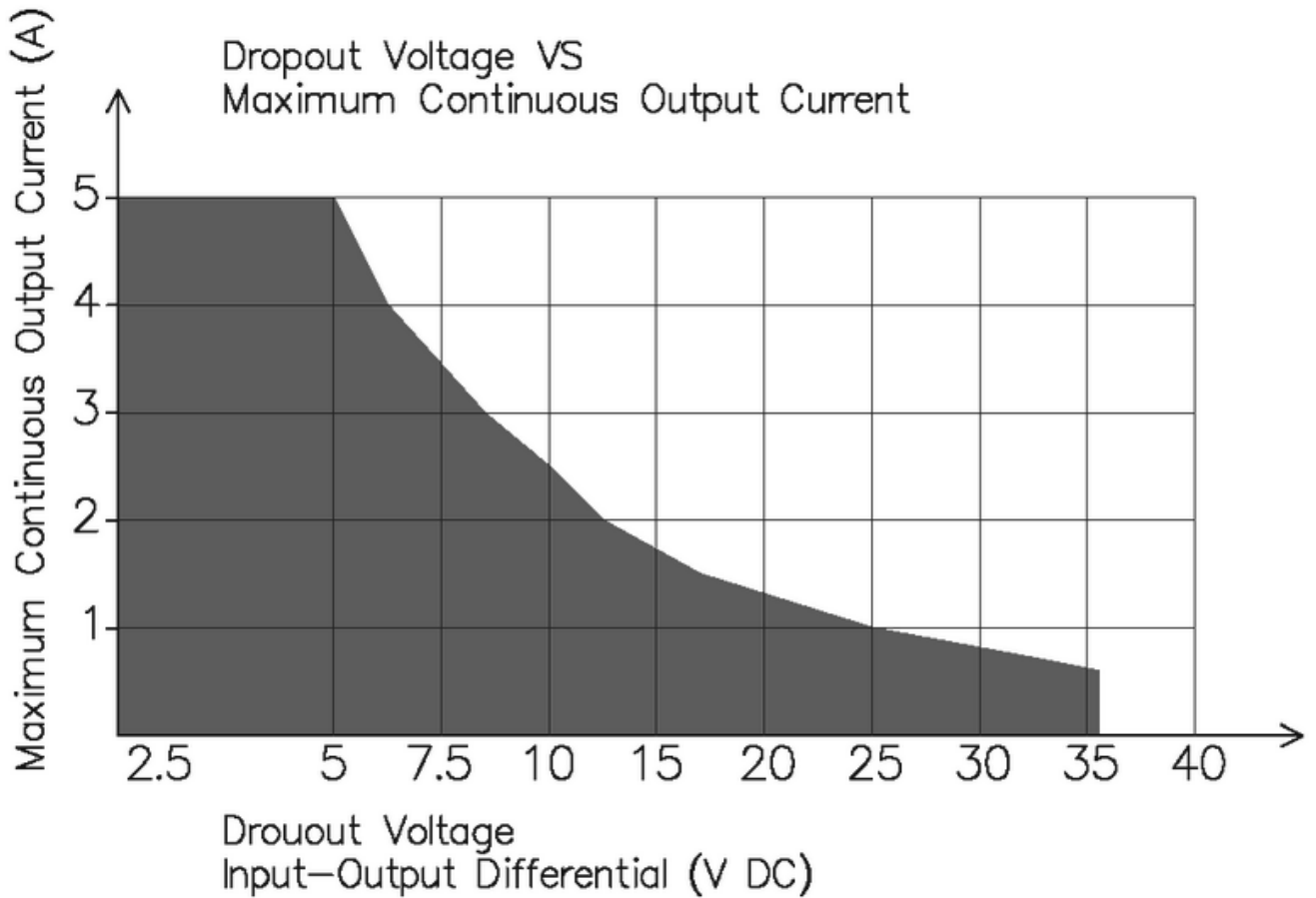

Input VS Output Range:

Input Voltage	Output range adjustable
DC 12V	1.5 to 9V DC
DC 18V	1.5 to 15V DC
DC 25V	1.5 to 22V DC
DC 35V	1.5 to 32V DC
AC 9V	1.5 to 8V DC
AC 15V	1.5 to 16.4V DC
AC 21V	1.5 to 25V DC
AC 26V	1.5 to 32V DC

Wiring diagram:

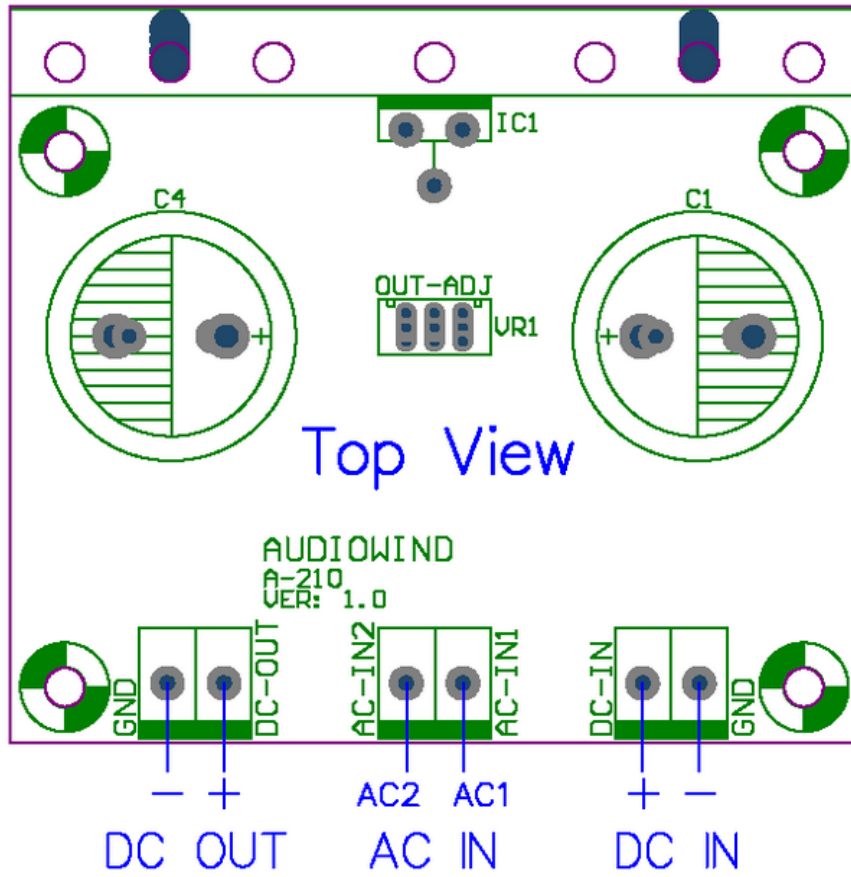

PCB Size:

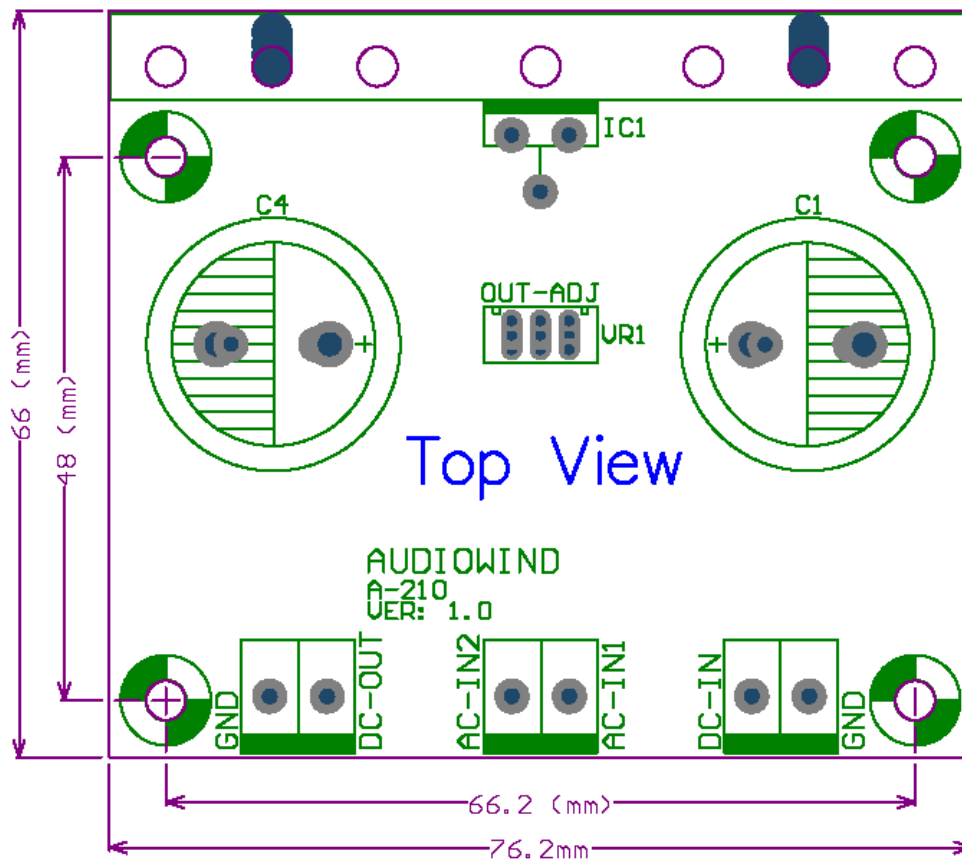

PCB Layout:

Top Layer

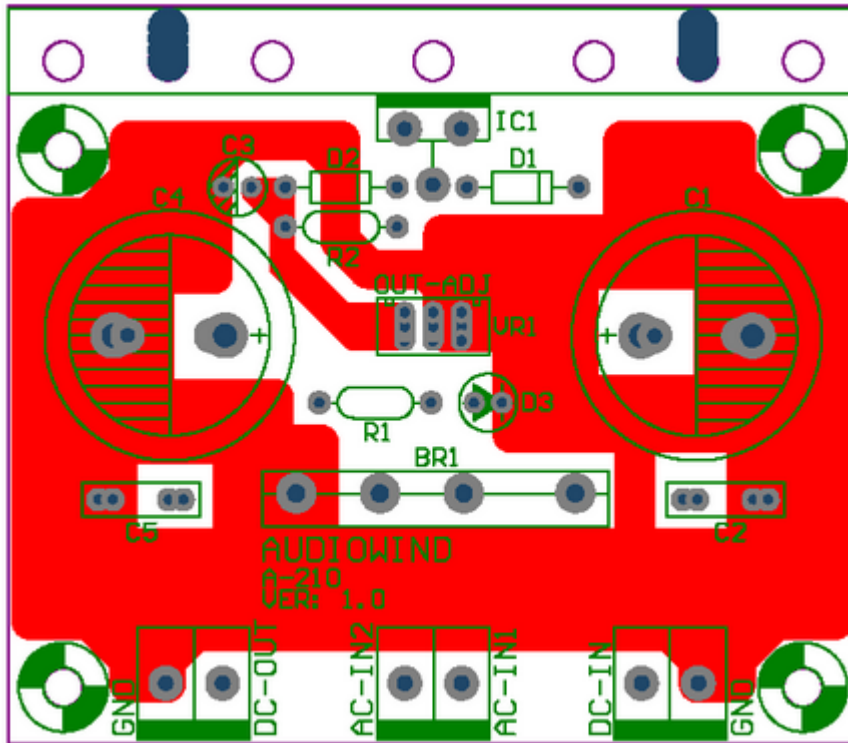

Bottom layer

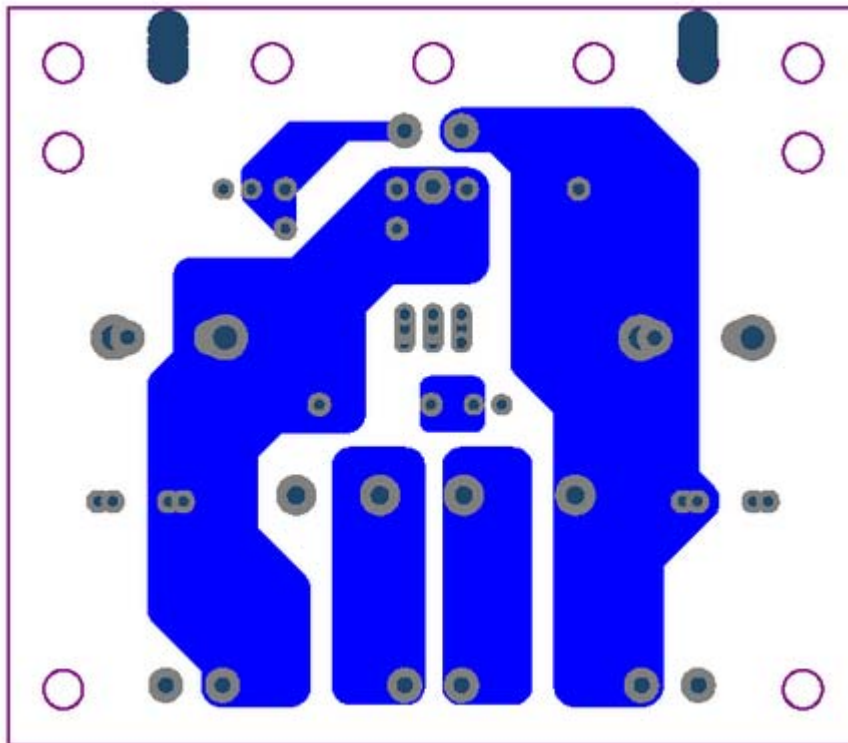

Potentiometer: L = 20mm.

Features / Individual Specification

Outline Drawing

Model

RV24

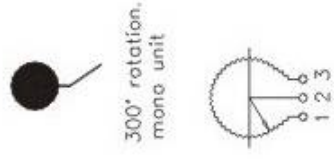
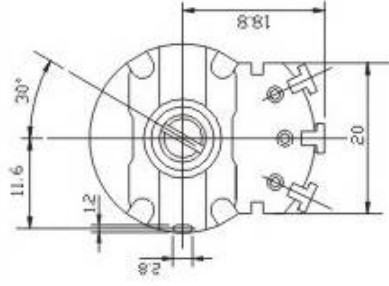
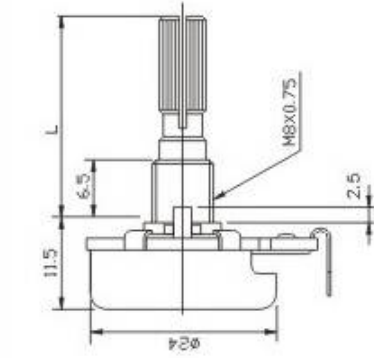

300° rotation.
mono unit