

Chunzehui Electronics-Salon CZH-LABS

Model: F-1006

Low Loss PWRpath Battery Backup Module

SUK: MD-F1006-1



The PWRpath is a simple DC backup power system. when the main Power Supply is on, the charging circuit charges battery until is full, and Output power is provided by the main Power Supply. when the main Power Supply is off, will switch to Battery, the Output will be battery powered. **Power Supply and Battery can be swapped out while equipment remains on, with no glitches.**

Features:

- Standard Powerpole connectors.
- Design based on powerpath controller and low loss MOSFETs (on status resistance 0.0023 ohm), you do not have to add heatsinks even for 30 Amps of continuous working current.
- Schottky diode and limiting resistor, constant voltage float charger, with charging indicator LED.
- High quality aluminum enclosure, thickness 1.5mm/0.06".
- Attachment includes: 3x black powerpole housings.
 - 3x red powerpole housings.
 - 3x PVC cover flame retardant sleeve.
 - 6x silver plated copper 30A 14-12AWG powerpole contacts.

Specification:

Operating voltage: DC 5 ~ 28V

Quiescent current: < 2mA (at 13.8V)

Max. output current: 40A (< 5 seconds)

Max. continuous output current: 30A

Voltage drop: 0.025V (at 10A)

0.070V (at 30A)

Switch circuit: Power MOSFETs "OR-gate" with powerpath controller.

MOSFETs: 30V 40A P-Channel, on status resistance 0.0023 ohm.

Charging circuit: Schottky diode and series limiting resistor, constant voltage float charger.

Connectors: compatible 45A powerpole connectors, **Red is positive, Black is negative.**

Charger current (Power Supply at 13.8V):

Battery at 10V, current 1160mA.

Battery at 11V, current 830mA.

Battery at 12V, current 510mA.

Battery at 13V, current 190mA.

Battery at 13.4V, current 66mA.

Battery at 13.6V, current 0mA.

Note: when charge current <30mA, the charger LED will is off.

Schematic diagram:

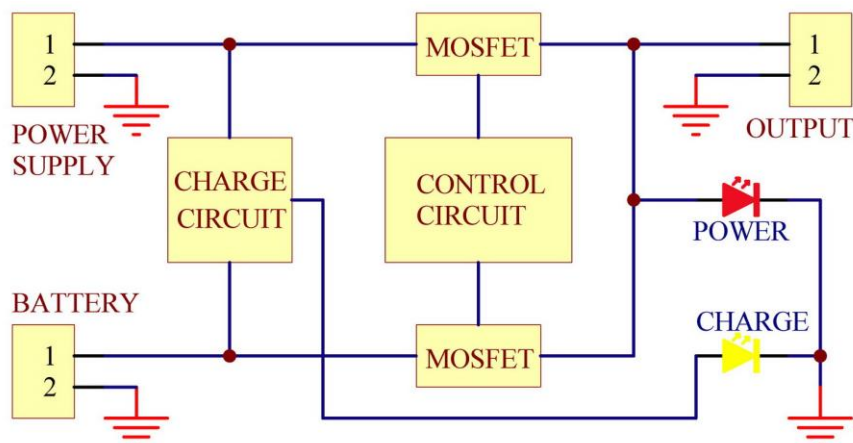

Dimensions:

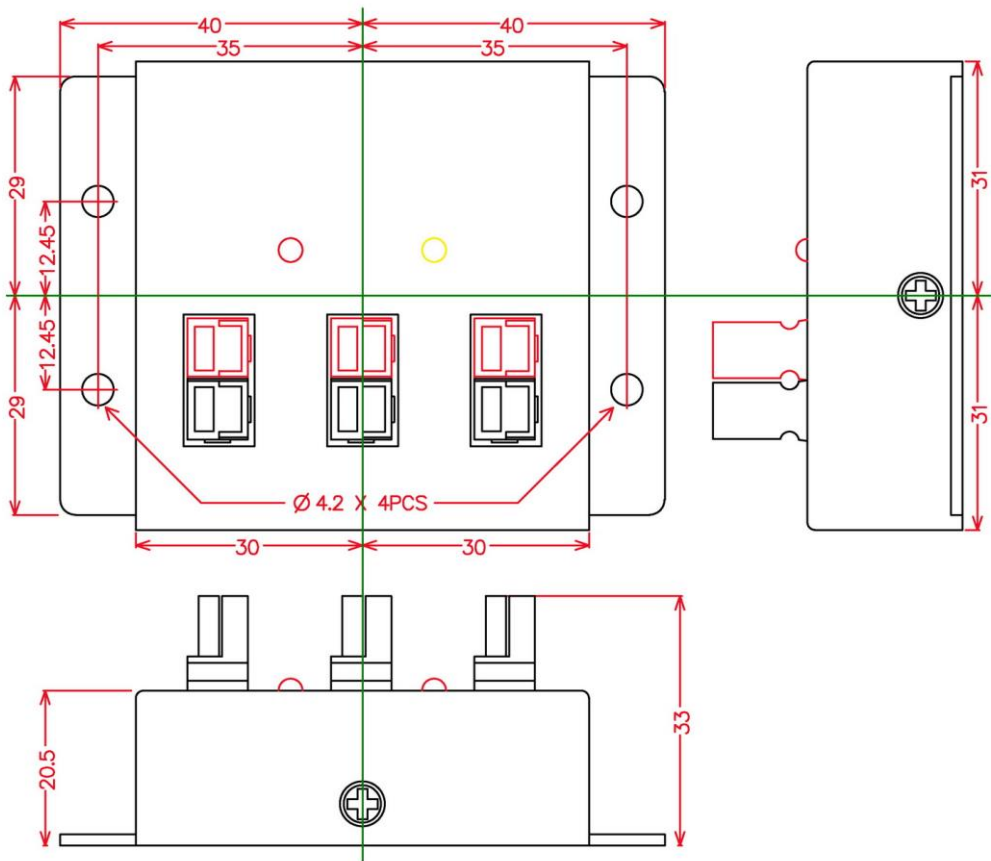



Power Supply



Battery



Load

